

Using **ShadeTree® Vinyl Overhead Tracks** supported by a vinyl support structure with **fixed - post placement**.

The Greenbriar



Dear Customer:

Thank you for purchasing our **ShadeTree® Canopy System**. We trust these assembly instructions will be satisfactory for your installation. If you have any questions, please feel free to call 1-800-894-3801.

And here's a special offer we'd like to make to you: Send us a photo of your new ShadeTree® installation and we will send you **\$50** if we use your photo in our advertising materials. Before and after pictures will receive an additional \$50. A deck or patio that is nicely furnished helps us communicate to prospective customers how nice a ShadeTree® patio can be.

We hope you enjoy your new ShadeTree® patio canopies.

Sincerely,

Dwayne M. Williams, President
ShadeTree Systems, LLC.

ShadeTree®
Retractable Patio & Deck Canopies

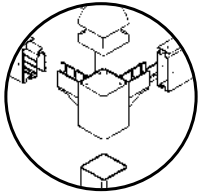

***Fixed-post Corner Bracket** with closed-ends provides a finished look in standard, fixed widths as shown below.

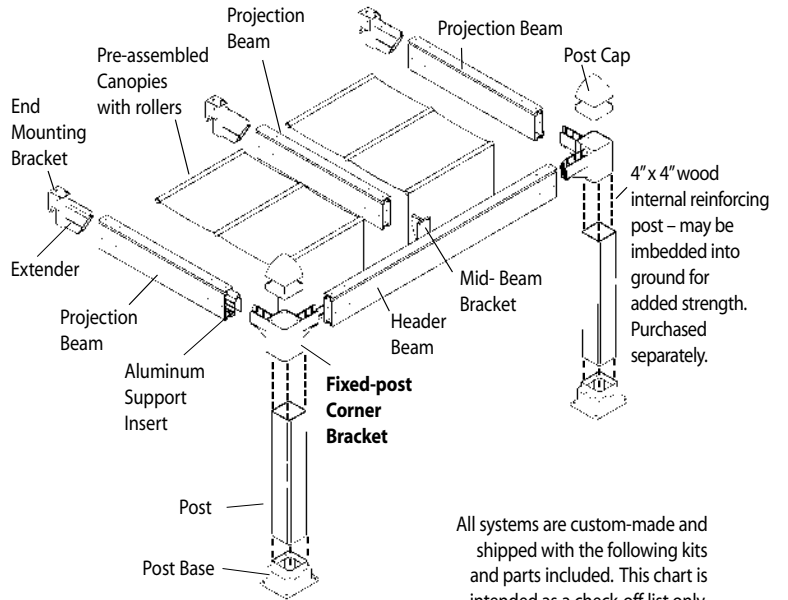

All systems are custom-made and shipped with the following kits and parts included. This chart is intended as a check-off list only.

Complete Vinyl System
(supported by an **vinyl** frame)

System **Widths:**

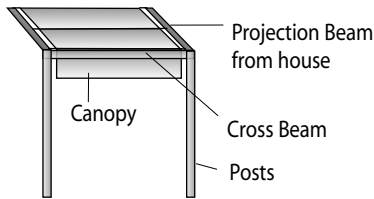

1 canopy section
5'-4" or 4'-2-1/4" wide*

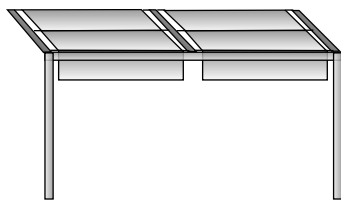

2 canopy sections
10'-8" or 8'-4-1/2" wide*

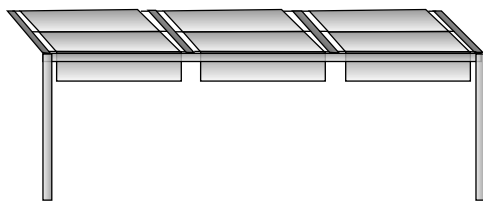

3 canopy sections
16' or 12'-6-3/4" wide*

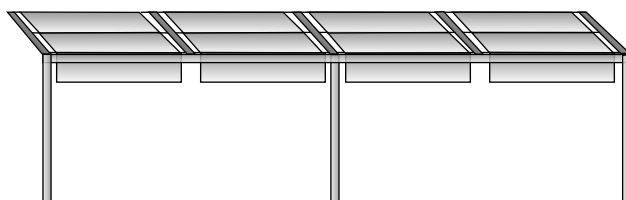

4 canopy sections
21'-4" or 16'-9" wide*

Parts for Vinyl ShadeTree® System
(utilizing fixed-post position support system)

	Quantity
ShadeTree® Canopies	1
Corners	2
Extenders	2
Projection beams	2
Header beam	1
Posts (4" x 4" x 10')	2
Posts – wood, 4" x 4" x 10' **	2
ShadeTree® Canopies	2
Corners	2
Extenders	3
Mid-Beam Position	1
Projection Beams	3
Header Beam	1
Posts (4" x 4" x 10')	2
Posts – wood, 4" x 4" x 10' **	2
ShadeTree® Canopies	3
Corners	2
Extenders	4
Mid-Beam Position	2
Projection Beams	4
Header Beam	1
Posts (4" x 4" x 10')	2
Posts – wood, 4" x 4" x 10' **	2
ShadeTree® Canopies	4
Corners	2
Extenders	5
Mid-Beam Position	2
Middle Position	1
Center Post-beam Hardware Kit	1
Projection Beams	5
Header Beam	2
Posts (4" x 4" x 10')	3
Posts – wood, 4" x 4" x 10' **	3

**** Purchased separately – should be longer if to be imbedded into ground.**

*center to center of outside projection beams. Please allow an additional 8" overall to accommodate mounting hardware and base fittings.

Fasteners & hardware provided:

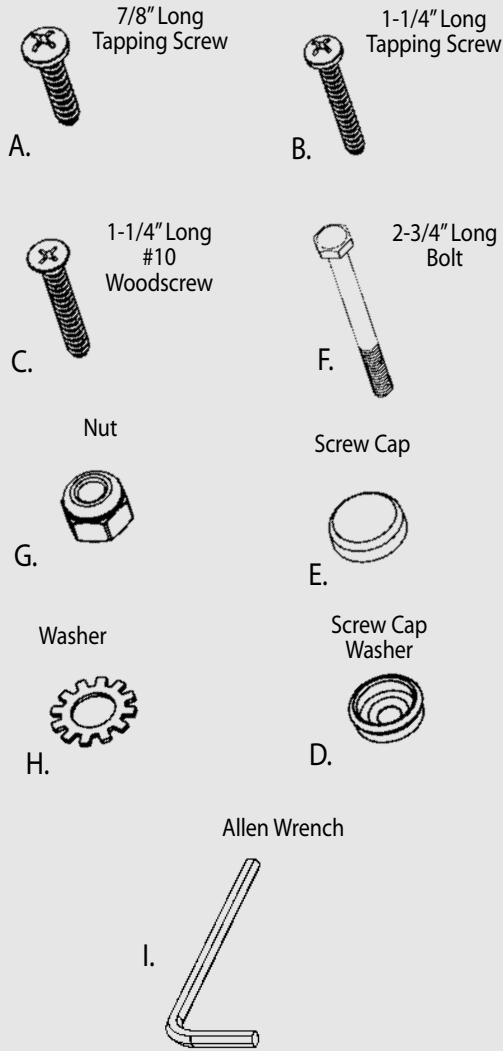

Note: All A & B screws should be assembled with screw cap washer (D.) As shown at right.

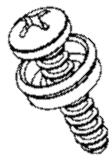

Tools required:

- 1. Phillips screwdriver
- 2. Hand drill
- 3. 9/64" drill bit
- 4. pencil
- 5. bubble-type level
- 6. Carpenter's square
- 7. tape measure
- 8. hand saw
- 9. 8' ladder

If driving screws with a drill or power screwdriver, set the torque to a low setting to avoid stripping screw heads.

Other Materials Required:

You will also need 4" x 4" wooden posts for added strength inside vinyl posts. Pre-selection of pressure-treated wood is very important. Any warped or oversized lumber will not fit inside the vinyl post. If sinking posts into the ground, treated lumber is recommended.

If mounting on a deck, patio, stepping stones, or wooden landscaping timber embedded into the ground, a wood post length of eight feet will suffice. If you wish to cement the posts 3' into the ground, 12' posts are needed. The vinyl framework should be completely assembled before cement is poured into the holes.

If you are sinking posts into the ground, the four *Post Bases* are optional. If you prefer to use the *Post Bases*, they should be assembled onto the vinyl *Posts* before erecting the system.

Optional:

Internal Post Anchor Bracket

For use in securing vinyl posts to concrete or decks, when sinking wood posts in the ground is not possible.

Call 1-800-894-3801 to order.
Part No. AS022 \$69.95 ea



NOTE: You'll find a second pair of hands (to hold parts as the unit goes up) to be very helpful in erecting your vinyl system.

Step 1 Attach End Mounting Brackets

Mark the center location for each *End Mounting Bracket* on the house 5'-4" or 4'-2" apart. One *End Mounting Bracket* is needed for every projection beam. Be sure to allow approximately 4" on the outside of outermost brackets for inserting bolts into brackets.

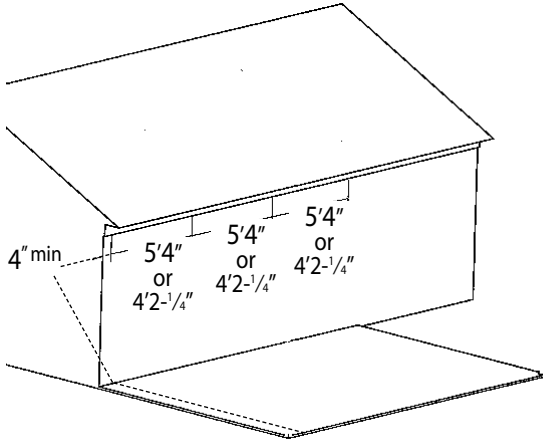

Mount the *End Mounting Brackets* on each center mark, using the center notch as a guide. The brackets should be mounted so that the slanting edge of the bracket is to the top (as in illustration). Be sure to mount the brackets level with each other. Use a 9/64" drill bit to drill pilot holes. Wood screws are included (1-1/4" screw c)... any other type of screws (such as masonry screws for brick or stone) can be purchased from your hardware store. The Bracket can be used as its own template for marking pilot holes.

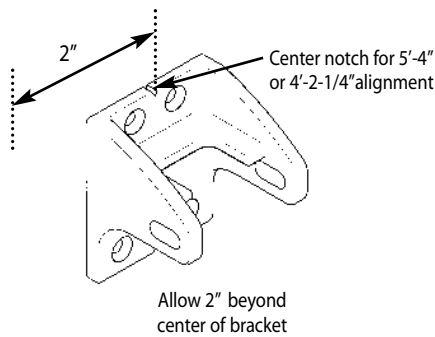

When mounting to house, brackets must be attached to well-secured wood, brick or stone.

- If mounting to a house with wood siding, or to wood trim, use the 1-1/4" #10 wood screws with the painted heads (screw c).
- If mounting to a masonry wall (brick or stone) concrete fastening screws must be used. Consult your hardware store for the best fastener for your situation.

- If attaching to stucco, aluminum, or vinyl siding, the screws must make contact with wood. On two story houses, this can usually be done in the area of the second floor joists. When no wood can be found to carry the canopy load, it is recommended to attach a 1" x 4" board to the home (see illustration below) . . . horizontally at the height desired for the canopy. The board can then be secured by screws into each stud. On aluminum or vinyl siding, tighten the bottom screws only enough to hold board snugly. Over-tightening can compress the siding. The board can be painted or stained to match the siding.

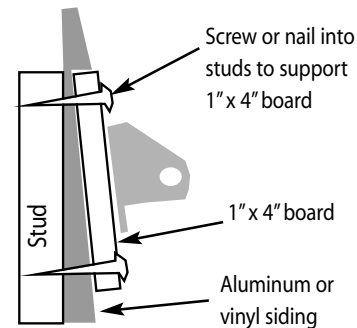

Step 2 Determine location of Posts

Measure out from the house to the desired location of your first vinyl Post (A). Measure out from the house a second time to the location of your second vinyl Post (B). Be sure that points A & B are on a line (C) that is parallel with the wall to which the End Mounting Brackets are attached.

To ensure that your system will be square, measure the distance from point B to point D. Then measure the distance from point A to point C. Move points A and B right or left to get B to D and A to C equal.

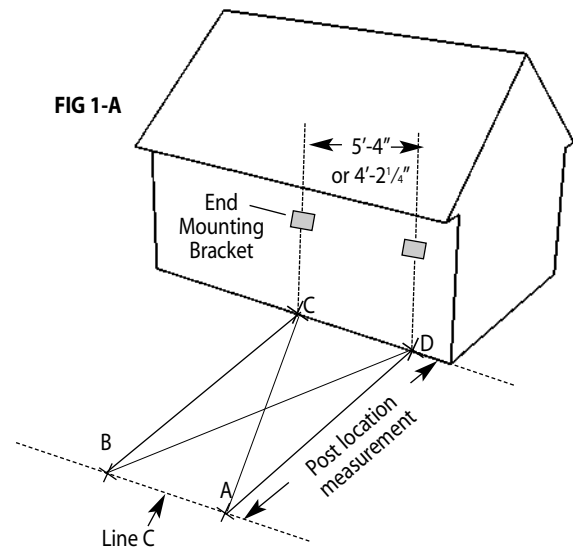

Step 3 Place One Post Base

It is important that your ShadeTree® structure be built on a level surface. It is highly recommended that the vinyl & wood posts be cemented 3' into the ground.

Place one post *Post Base* in the desired location. Ensure that this location is directly opposite the *End Mounting Brackets* you attached in step 1. Do not fasten to the mounting surface at this time.

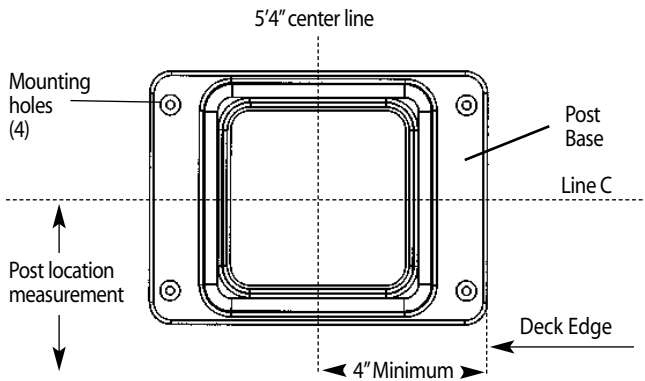

Step 4 Erect first Post

Slide a wood post into one vinyl *Post* and then insert one end of that *Post* into the *Post Base*.

Drill eight 9/64" holes through the existing *Post Base* holes into the wood post. Do not yet use the 1 1/4" Tapping Screws (B) to tighten *Post Base* to *Post*.

Slip one *Corner Bracket* over the upper end of the first vertical *Post*. Slide it down to the approximate desired height. To hold the *Corner Bracket* temporarily in place until final leveling adjustments are made, tighten the *Corner Bracket* set screw using the Allen Wrench (I) provided.

Have your helper hold the post upright for the next step.

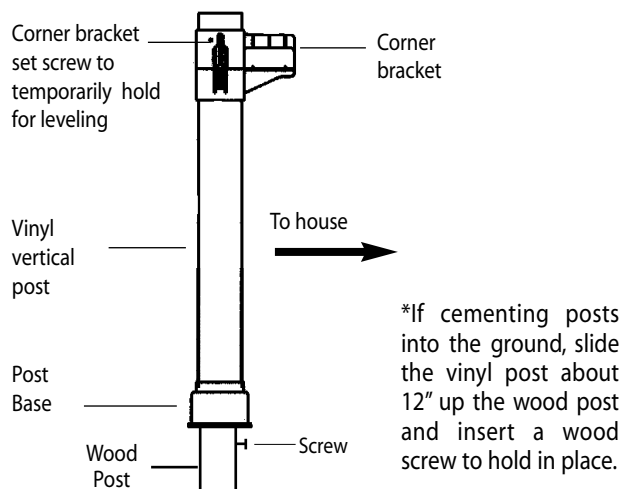

Step 5 Attach Extenders

Attach an *Extender* to each of the *End Mounting Brackets* on the house using the 2-3/4" bolts (F), lock washers (H) and nuts (G) provided. Be sure the top of the *Extender* is up (as shown.) Loosely hand-tighten the nuts.

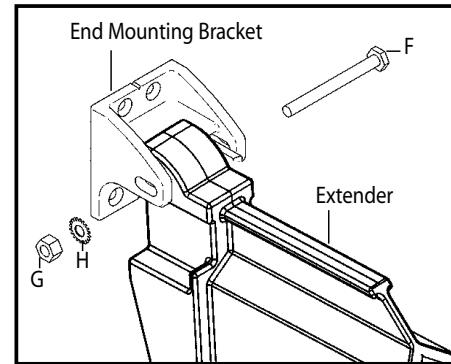

Step 6 Measure the length of the Projection Beams

Have your helper hold the *Post Assembly* square. Hold the *Extender* level. Measure the distance from the *Extender* to the *Corner Bracket* as shown in the illustration below. This measurement will tell you exactly how long your *Projection Beams* must be. Compare this measurement to the actual length of the *Projection Beams* that you purchased to determine how much needs to be cut (if any.)

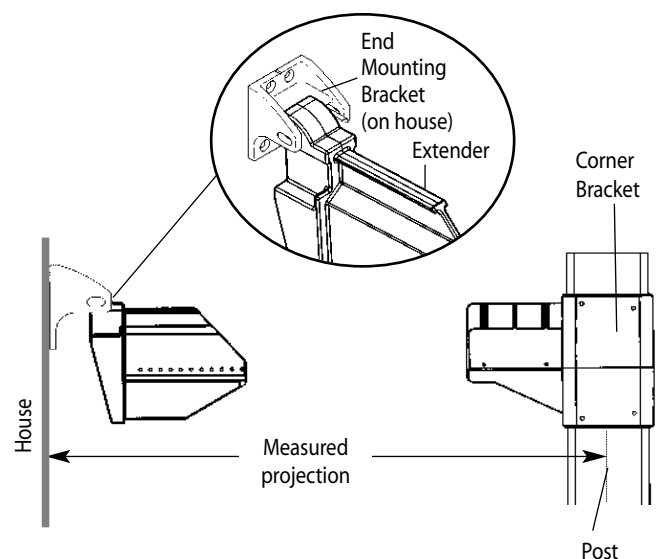

If your application requires projection beams shorter than provided, please follow step 7 on next page. If you are satisfied with the projection length, proceed to step 8.

Step 7 Shorten Projection Beams (optional)

Cut the desired length off one end of the *Projection Beam* with a hack saw or miter saw. It is recommended to cut the length from the end of the *Projection Beam* closest to the house. Ensure that the cut is square. Redrill the six mounting holes in the end of the *Projection Beam* using the 9/64" drill bit. For the holes on top of the *Beam*, measure along the scribed centerline already present on the *Beam*. Drill the hole locations per the dimensions shown below. For the holes on the side of the *Beam*, drill four 9/64" holes per the dimensions shown below. Repeat this process for all *Projection Beams*.

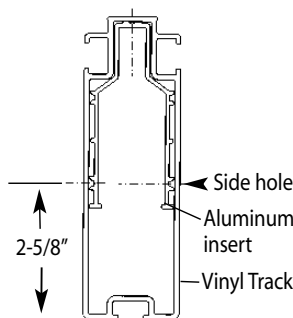
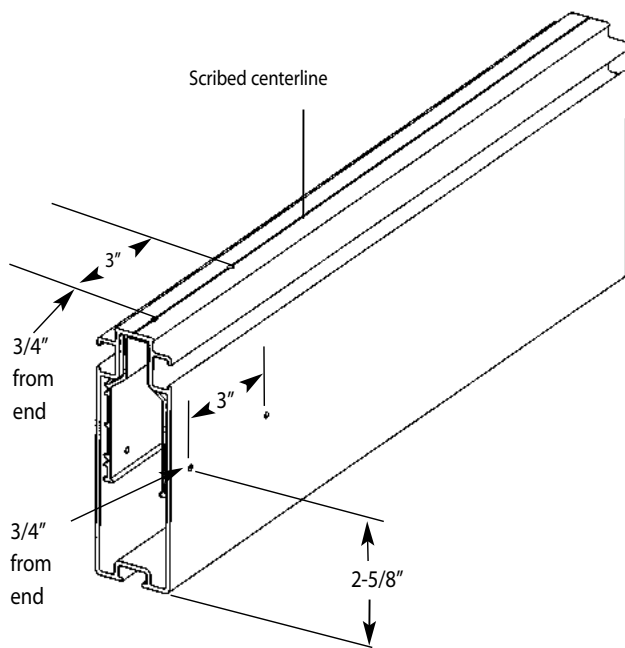

Step 8 Connect outside Projection Beams

Assemble the outside *Projection Beam* to the existing post assembly.

Insert the arm of the *Corner Bracket* and the arm of the *Extender* into the *Projection Beam*. Ensure that the vertical *Post* is square with the mounting surface and the *Projection Beam* is square with the house. Slide the *Post Base* down to the mounting surface and secure the *Post Base* to the *Post* using the 1-1/4" Tapping Screw (B). You will be screwing into the eight 9/64" holes you drilled in step 4.

To help secure the *Projection Beam* during the assembly process, insert two 7/8" tapping screws (A) into the *Projection Beam* through both the *Extender* and the *Corner Bracket*. The two holes on the top of the track at the *Extender* connection must be drilled into the *Extender* with the 9/64" drill bit to a depth of approximately 1".

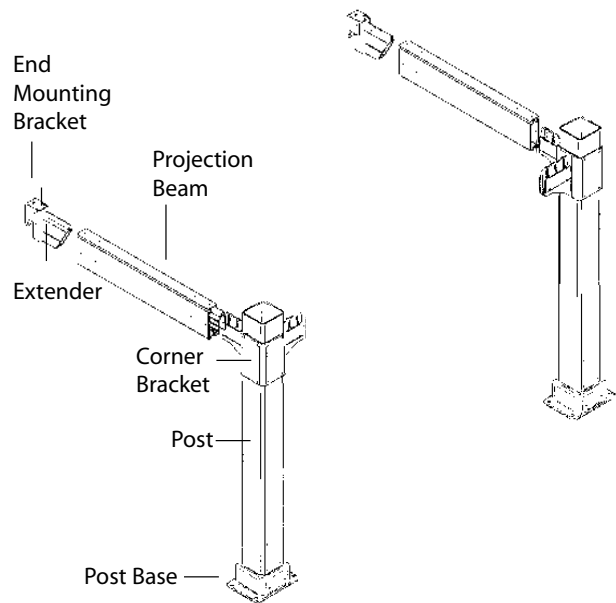

Repeat steps 5 through 7 for the other outside *Projection Beam*. If cementing posts, square all vertical posts using a bubble level. Add cement to holes & resume assembly once cement is dry.

Step 9 Connect Posts

Assemble the *Header Beam* to the *Projection Beam/post* assembly. Have your helper hold one vertical *Post* in position while you steady the 2nd vertical *Post*. Insert the arm on the *Corner Brackets* into the *Header Beam* on both ends.

Place a bubble level on top of the *Header Beam* to confirm that it is level. If it is not, loosen the set screws on the *Corner Brackets* and lower or raise the *Corner Brackets* on the *Post* as necessary. Once level, drill eight 9/64" holes through the existing mounting holes on the *Corner Bracket* and into the *Post*. Fasten each corner with eight 1-1/4" Tapping Screws (B).

To secure the *Header Beam*, screw two 7/8" Tapping Screws (A) through the pre-drilled holes on the top of the *Header Beam* into the *Corner Brackets* at both corners.

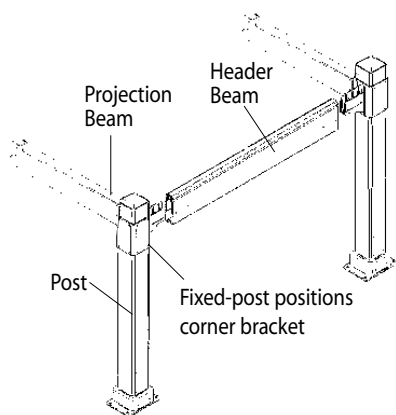

Step 10 Assemble Mid-beam Bracket

If you have purchased a one-canopy system, skip steps 9 & 10. Measure inward from the centerline of the outside track 5'-4". Place the *Mid-beam Bracket* on the cross beam at this distance. This location should be directly across from the *End Mounting Bracket* on the house (step 1.) Using the *Mid-beam Bracket* as a template, mark the four mounting hole locations. Remove the bracket and drill through one side of the *Header Beam* and its aluminum insert with the 9/64" drill bit. Secure the *Mid-beam Bracket* in place with four 7/8" Tapping Screws (A).

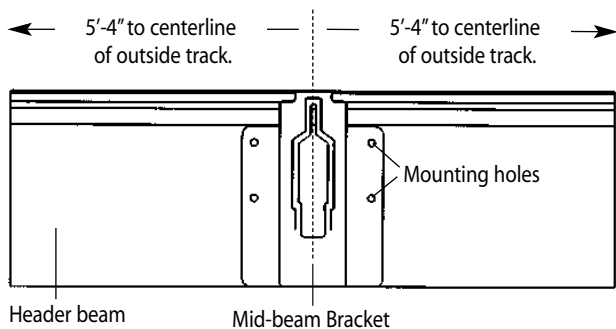

Step 11 Connect Middle Projection Beam

Insert the arm of the *Extender* and the arm of the *Mid-beam Bracket* into the *Middle Projection Beam*. Secure the beam by inserting two 7/8" Tapping Screws (A) into the beam at each end.

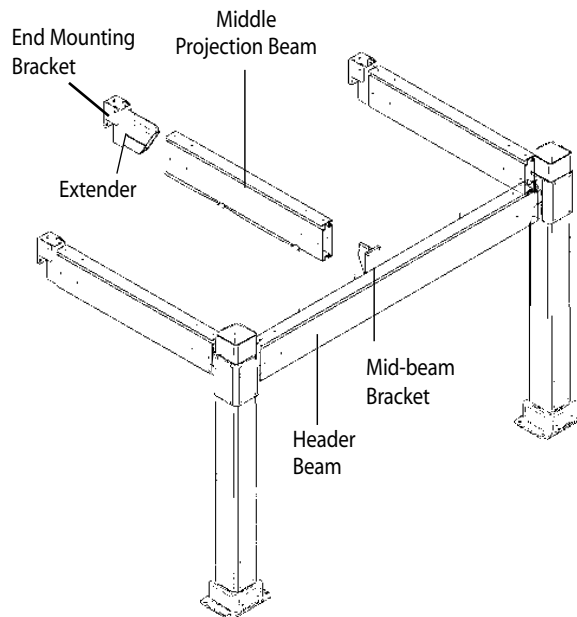

Step 12 Fasten the system together

If the posts are cemented, remove the screw holding the vinyl posts up and slide the vinyl posts back down the wood posts. Use a square and a level to make sure the posts are all square and the beams are level. Proceed to insert screws into all remaining fastening points. The quantity, type, and location of all screws is shown below.

Be sure to use the plastic washer on each screw so a plastic cap can be applied to cover the screw.

For a guide to screw hardware see page 3.

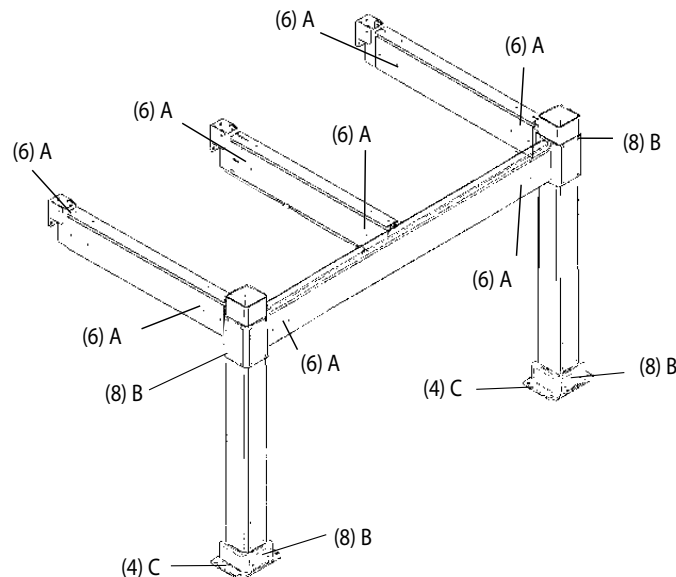

Step 13 Attach Caps to Posts

If more than 2" of Post is exposed above the Corner Fitting, you can cut the excess with a saw before assembling the Post Caps. Place one Post Cap on top of each Post. If you wish to secure the cap permanently on top of the Post, apply a bead of clear silicon caulk (not provided) to the inside wall of each cap before assembly.

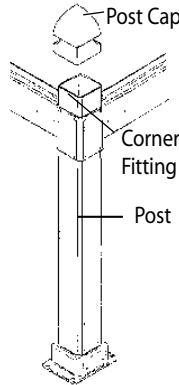

Step 14 Shortening Canopy Length (optional)

Lay the canopy on a flat clean surface. The extra fabric length should be removed from the back end of the canopy. This is the end opposite the handle. Remove the Roller Sleeve assemblies at both ends of the back canopy Cross Member. To do this, first fully extend the Roller, then push down on the locking tab and pull Roller Sleeve outward (Fig. 2A).



Remove the Fabric Clamp. To do this, insert a flat head screw driver between the canopy fabric and the Fabric Clamp. Pry upward to release the Fabric Clamp (Fig. 2B).



From the back end of the canopy, measure the same distance that was taken off the track length. Make a mark at this distance on both outside edges of the fabric (Fig. 2C).



Place the Bottom Cross Member (aluminum) underneath the canopy, centering it on the two marks. Position the Bottom Cross Member so the punched square holes at the ends are facing downward. Holding the Bottom Cross Member in this position, reassemble the Fabric Clamp by snapping the Fabric Clamp in place at both ends and pressing down, working toward the center (Fig. 2D).

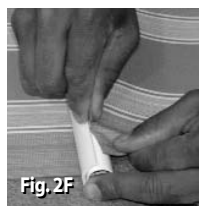

Insert the Roller Sleeve assemblies back into the Bottom Cross Member, ensuring that the locking tab engages the corresponding punched square hole in the Bottom Cross Member (Fig. 2E).

Measure the canopies to ensure the desired length is correct before trimming off excess canopy material. Remove the canopies and place on a flat, clean surface. To remove the excess canopy material, use the edge of the Fabric Clamp as a guide when cutting with a sharp utility knife (Fig. 2F).

Step 15 Installing the Canopies

You can now insert the Canopies, starting at the end of the beams closest to the house. Insert the Rollers at the ends of each Cross Member; insert the front Cross Member first. The front Cross Member is the one that has a Slide Lock on each end. When inserting, ensure that the Lock Tab is pointing up as shown here. Be sure that the canopy is oriented so that the Fabric Clamp is facing up as shown, while the aluminum Cross Member is oriented down. Continue inserting the remaining rollers until the entire Canopy is up. Install remaining Canopies using the same procedure.

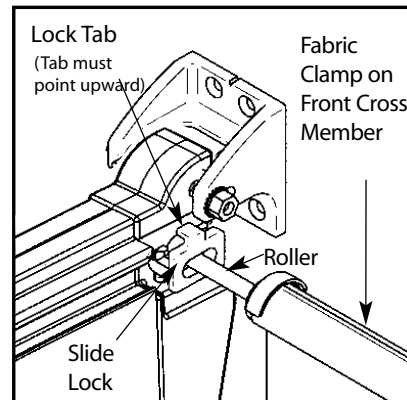

Step 16 Locking the end of the canopy

A Roller Lock Pin is provided to hold the Cross Member nearest the house in a fixed position. It will arrive already inserted in the canopies in the last cross member. Once in place, it can be secured with set screws. The locking pin will hold the last Cross Member firmly in place. Repeat on each track. (On masonry houses, it is recommended to leave a few inches between the canopy and the house to prevent scuffing of the canvas during windy weather).

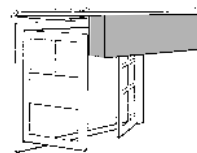
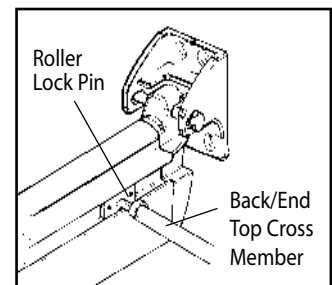

If existing obstacles (casement windows, doors, etc.) keep canopies from retracting against the house, **extra canopy roller locks** can be inserted into the tracks and hooked

onto the next rollers on the canopies. As a result, canopies will retract only to the desired position, clearing the obstacle.

Step 17 Installing the Top Lock Brackets

Pull each canopy section out to the position where you want it to end. Place a *Top Lock Bracket* on the top of the track in the orientation shown in Fig.2A. Tighten set screw 1 on both sides of the *Top Lock Brackets* with the Allen wrench provided (I) . . . making sure that the *Top Lock Brackets* are completely pushed down on the track before tightening.

Test the snap-in *Top Lock Bracket* and tighten or loosen the adjusting screws as required for the desired tension. The recommended tension setting procedure is to turn the adjust screw clockwise until it stops, and then back the adjust screw out six full revolutions Repeat this step on each lock mechanism.

Pull each canopy back to the fully retracted position. Place another *Top Lock Bracket* on each track at this point, in the orientation shown in Fig.2A. Tighten the set screws.

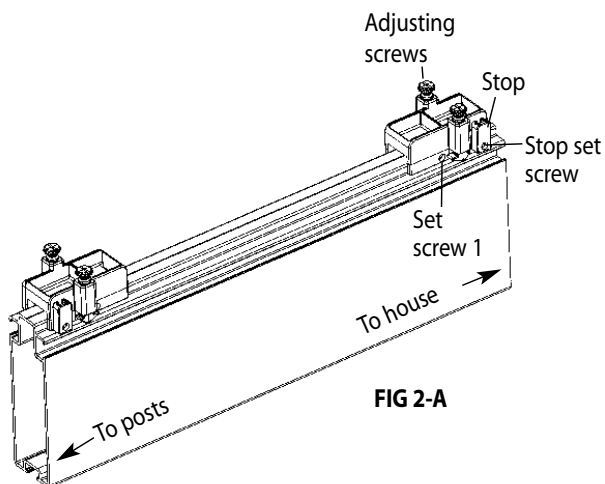

NOTE: The locking system is designed to release the canopies in high winds to protect the canopies. The adjusting screws can be used to adjust the tension. Do not over-tighten, as this could increase the chance for canopy damage in high winds.

Step 18 Assemble Screw Caps

Locate the small white Caps (E) in the hardware packet and snap the caps onto the screw cap washers (D).

Step 19 Adjusting the handle height (optional)

Each canopy has the handle overhang approximately 18" from the tracks. This drop handle is for opening and closing the canopies. However, if you must have less than an 18" overhang, follow the instructions below for shortening the handle height.

1. Remove all screws in the handle and open the handle the entire width.
2. Cut the fabric to the desired length.
3. Carefully close the handle and re-insert the screws provided - do not overtighten.
4. Reinstall the top caps in the end of the handle.

Care and cleaning of your ShadeTree® Canopies

1. **ShadeTree® tracks** should be cleaned regularly to keep debris and dirt from accumulating and interfering with the rollers. Simply use a mild detergent with a small soft brush, such as a toothbrush, and gently wipe or brush along the inside of the tracks. To maintain a smoothly operating system, apply a paste car wax such as Kit™ or Turtlewax™ to the roller tracks. Allow the wax to dry then wipe off with a clean, soft cloth. **Note: Do NOT use oil or any wet lubricant, such as WD-40, on the tracks as it would attract more dirt.** For ultimate performance, use **ShadeTree® EasyRider Track Lubricant**.
2. **Fabric** should be cleaned regularly before substances such as dirt, roof particles, etc., are allowed to accumulate on and become embedded in the fabric. The fabric can be cleaned without being removed from the cross members. Simply brush off any loose dirt, roof particles, etc.; hose down and clean with a mild natural soap in lukewarm water (no more than 100° F.) Rinse thoroughly to remove soap. **DO NOT USE DETERGENTS!** For ultimate performance, use **ShadeTree® Canopy Cleaner Mold & Mildew Stain Remover**.
3. For stubborn stains soak the fabric for approximately 20 minutes in a solution of no more than 1/4 cup (2 oz.) natural soap per gallon of water at approximately 100° F. Rinse thoroughly in cold water to remove all of the soap. Note: Excessive soaking in bleach can deteriorate sewing threads. This method of cleaning may remove part of the water repellency and the fabric should receive an application of an air-curing water-repellent treatment, such as APCO, UNISEAL, SUNSEAL or similar products, if water repellency is a factor. For ultimate performance, use **ShadeTree® Canopy Cleaner Mold & Mildew Stain Remover** and **ShadeTree® Water Repellent**.
4. When washing or cleaning, **DO NOT SUBJECT TO EXCESSIVE HEAT** as the fabric will shrink. **DO NOT STEAM PRESS OR DRY IN ELECTRIC OR GAS DRYERS**, but allow to air dry.
5. In cases where canopies are taken down & stored, they should be cleaned and allowed to air dry, before being stored in a dry, well ventilated area.

How to **remove** ShadeTree® Canopies for **end-of season storage**:

1. Remove the **Top Lock Brackets** at the “retracted” end of each track (see step 16.)



- 2 Remove the **Roller Lock Pin** which holds the last Cross Member in a fixed position (see step 15.)



3. Then simply roll the **Cross Members** out of the “retracted” end of the track. The tracks can remain up year-round.
4. **If a canopy is dirty** and requires washing before storage, simply spread the canopy on a driveway or other flat surface. Wash, using a broom and bucket of warm water and a mild soap, such as Ivory Snow.

Be sure to rinse well by hosing with a clear water. Allow to air-dry completely in the sun before rolling canopies up for storage. **(Do not store wet canopies!)**

Here's a chance to earn **\$50!**

We regularly use pictures in our advertising materials. If you send us reproducible pictures of your new ShadeTree® canopy installation, and we use them in any of our advertising, we will send you \$50. Interesting before-and-after pictures will receive an additional \$50. Of course, attractive landscaping and patio furniture will be a factor in selecting pictures to be used. Architects, builders and installers will receive credit mentions in the advertising.

ShadeTree® Canopy System Products

What/who is covered and for how long

ShadeTree® Systems, LLC (ShadeTree) warrants to the original property owner/purchaser that its ShadeTree Canopy System products, when subject to normal and proper use, will be free from the manufacturing defects enumerated below. Should any enumerated defects occur during the specified time period following installation, ShadeTree will repair the defective ShadeTree System product or provide replacement material, at its option. ShadeTree also reserves the right to refund to the original owner the amount paid by the original owner for the defective ShadeTree System product (but not including the cost of labor related to its initial installation).

ShadeTree shall in no event be liable for labor charges or other expenses whatsoever in connection with removal or installation of either the original or replacement product. In the event of repair or replacement under the terms of this warranty, the original warranty shall apply to the replacement or repaired ShadeTree System component and will extend for the balance of the warranty period in effect at the time the component proved defective.

ShadeTree® Canopy System components carry the following warranties:

Canopy fabric

All fabrics are warranted by ShadeTree® for five years following installation against fading, rotting and mildew.

Posts, aluminum and vinyl tracks

All posts and overhead tracks are warranted for ten years following installation against breakage.

System hardware

All connectors and other hardware are warranted to remain operable for five years following installation.

Limitations

This warranty does not provide protection against any failure, defect or damage caused by situations and events beyond normal exposure conditions, including, but not limited to:

- misuse, abuse, neglect or improper handling or storage;
- improper installation or installation not in strict adherence to ShadeTree's written instructions;
- use of accessories which do not properly receive and/or secure ShadeTree® Canopy System products;
- impact of foreign objects, fire, earthquake, flood, high winds, lightning, hail, hurricane, tornado or other casualty or act of God;
- movement, distortion, collapse or settling of the ground or structure on which the ShadeTree® Canopy System product is installed;
- any other cause not involving enumerated manufacturing defects in the Canopy System product supplied by ShadeTree.

Transferability

This warranty is not transferable.

Other conditions

This warranty replaces all other oral or written warranties, liabilities or obligation of ShadeTree, pertinent state law shall control for what period of time following the sale a property owner/consumer may seek a remedy under the implied warranty of merchantability or of fitness for a particular purpose. In no event shall ShadeTree be liable for consequential or incidental damages of any kind resulting from the breach of this warranty. No field representative of ShadeTree or any distributor or dealer is authorized to make any change or modification to this warranty. Some states do not allow limitations on, or the exclusion of, incidental or consequential damages, so the above exclusions may not apply to you.

The warranty value is "pro-rated" based on invoice date and is not a full replacement warranty.

This warranty gives you specific legal rights, and you may also have other rights which may vary from state to state.

What the consumer must do:

The property owner/consumer must keep the original invoice as proof of date of purchase and installation, in case a warranty claim is made.

Notify ShadeTree in writing of any manufacturing defect promptly following its discovery and provide proof of the date of purchase and installation, as well as proof of property ownership. All notifications should be sent to:

ShadeTree® Systems, LLC
6317 Busch Blvd.
Columbus, OH 43229
Attn: Warranty Service Department

The property owner/consumer will be required to submit the defective material to ShadeTree for analysis. (ShadeTree will accept pictures of the larger items such as posts, and tracks.) ShadeTree will then investigate the claim and examine the material claimed to be defective. ShadeTree, at its sole discretion, will determine if a warranty claim is justified or not. If a defect covered by this warranty is confirmed, ShadeTree, within a reasonable amount of time after the inspection, will repair or provide replacement material, or refund the amount paid by the original owner for the defective product per the terms of this warranty.



This warranty is effective for products purchased after October 15, 2001.



40-75-137
Printed in U.S.A.

6317 Busch Blvd. • Columbus, Ohio • 43229 • 800-894-3801 • FAX 614-844-5991
© 2008 ShadeTree Systems, LLC. ShadeTree® is a registered trademark of ShadeTree Systems, LLC. ShadeTree® U.S. patent #5794679 & 6006809. International patents pending. Sunbrella® is a registered trademark of Glen Raven Mills, Inc.