

Using **ShadeTree® Aluminum Overhead Tracks**
supported by a wood support structure erected on site.

The Forester



Dear Customer:

Thank you for purchasing our **ShadeTree® Canopy System**. We trust these assembly instructions will be satisfactory for your installation. If you have any questions, please feel free to call 1-800-894-3801.

And here's a special offer we'd like to make to you: Send us a photo of your new ShadeTree® installation and we will send you **\$50** if we use your photo in our advertising materials. Before and after pictures will receive an additional \$50. A deck or patio that is nicely furnished helps us communicate to prospective customers how nice a ShadeTree® patio can be.

We hope you enjoy your new ShadeTree® patio canopies.

Sincerely,

Dwayne M. Williams, President
ShadeTree Systems, LLC.





Canopies supported by a **wood** frame

These instructions assume one end of the tracks will be attached to the house and the other to wood frame supports constructed on site. It is recommended that the vertical posts of the wood support frame be constructed of at least 4" x 4" lumber. Construction of vertical posts with 2" x 4" lumber is discouraged. There are only small differences between standard track and Heavy Duty Track for projections over 16'. Look for *'s to find special instructions for Heavy Duty Track.

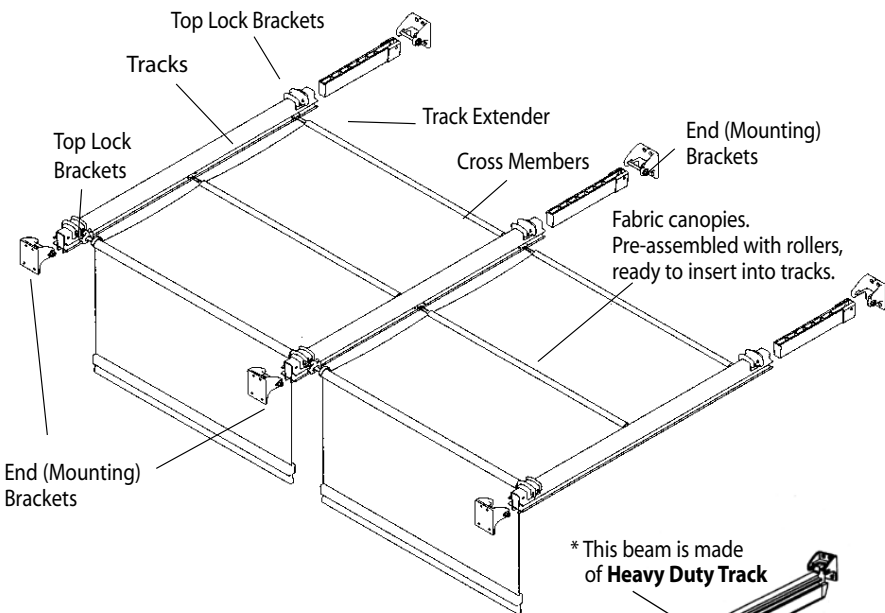

You can support your ShadeTree® Forester Model with a simple wood frame:

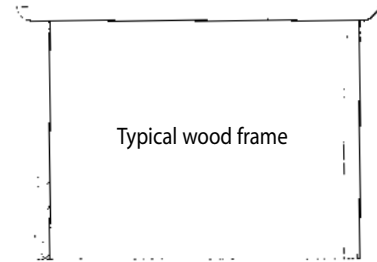

Aluminum Overhead System (supported by a **wood** frame)

All systems are custom-made and shipped with the following kits and parts included. This chart is intended as a check-off list only.

System Width:

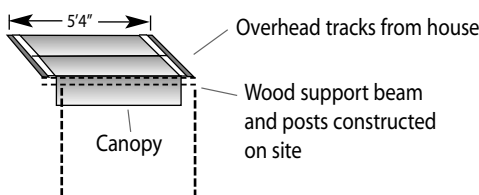

1 section
5'-4" or 4'-2-1/4" wide*

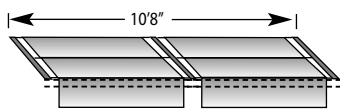

2 sections
10'-8" or 8'-4-1/2" wide*

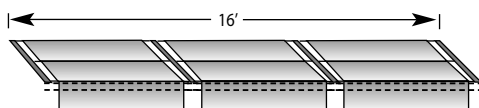

3 sections
16' or 12'-6-3/4" wide*

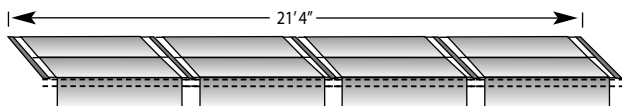

4 sections
21'-4" or 16'-9" wide*

Parts for The Forester Canopy System (using aluminum tracks)

	Quantity
ShadeTree® Canopies	1
Track Hardware Kit	2
Tracks	2
<hr/>	
ShadeTree® Canopies	2
Track Hardware Kit	3
Tracks	3
<hr/>	
ShadeTree® Canopies	3
Track Hardware Kit	4
Tracks	4
<hr/>	
ShadeTree® Canopies	4
Track Hardware Kit	5
Tracks	5

*on center of outside tracks. Please add an additional 4" to total width for mounting brackets (2" on each side).

Fasteners & hardware provided:

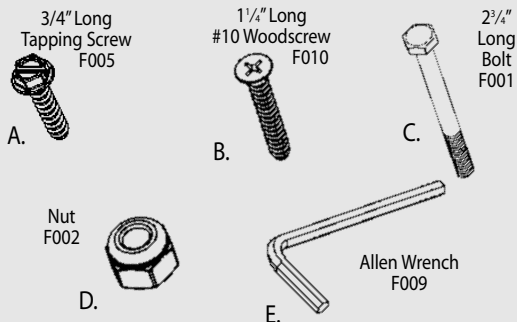

Tools required:

- | | |
|-------------------------|----------------------|
| 1. Phillips screwdriver | 6. bubble-type level |
| 2. hand drill | 7. tape measure |
| 3. 3/16" drill bit | 8. hacksaw |
| 4. 1/8" drill bit | 9. 8' ladder |
| 5. pencil | |

Step 1 Attach End Mounting Brackets

Mark the center location for each *End Mounting Bracket* (one at each end of the track) on the wood support system and on the house. The marks made should be placed 5'-4" or 4'-2-1/4" apart. Be sure to allow approximately 2" on the outside of each outermost mark for inserting bolts into the brackets.

Mount the *End Mounting Brackets* on each center mark, using the center notch as a guide. The *Brackets* should be mounted so the slanting edge of the bracket is to the top (as in illustration). Be sure to mount the brackets level with each other. Drill four pilot holes with a 1/8" drill bit. Fasten the *Bracket* with four 1-1/4" long #10 Wood Screws (B) ... any other type of screws (such as masonry screws for brick or stone) can be purchased from your hardware store. The *Bracket* can be used as its own template for marking pilot holes.

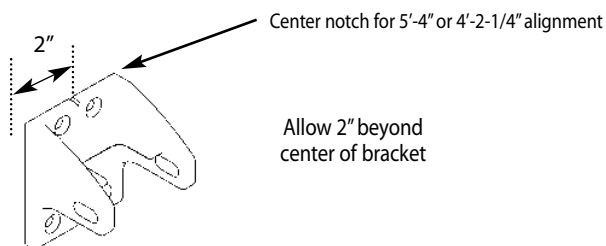

When mounting to house, brackets must be attached to **well-secured** wood, brick or stone.

- If mounting to a house with wood siding, or to wood trim, use the 1-1/4" long #10 Wood Screws (B) provided.
- If mounting to a masonry wall (brick or stone) concrete fastening screws must be used. Consult your hardware store for the best fastener for your situation.
- If attaching to stucco, aluminum, or vinyl siding, the screws must make contact with wood. On two story houses, this can usually be done in the area of the second floor joists. When no wood can be found to carry the canopy load, it is recommended to attach a 1" x 4" board to the home (see illustration below) ... horizontally at the height desired for the canopy. The board can then be secured by screws into each stud. On aluminum or vinyl siding, tighten the bottom screws only enough to hold board snugly. Over-tightening can compress the siding. The board can be painted or stained to match the siding.

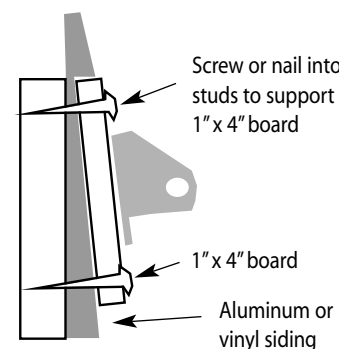

Step 2 Attach Extenders

Attach an *Extender* to each of the *End Mounting Brackets* that are mounted on the house, using the 2-3/4" bolts (C) and nuts (D) provided. Be sure the top of the *Extender* is up (as shown). Loosely hand-tighten the nuts.

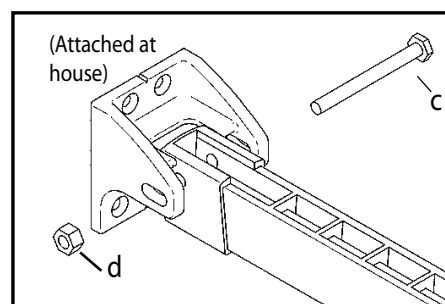

*Extenders are used on both ends when using Heavy Duty track.

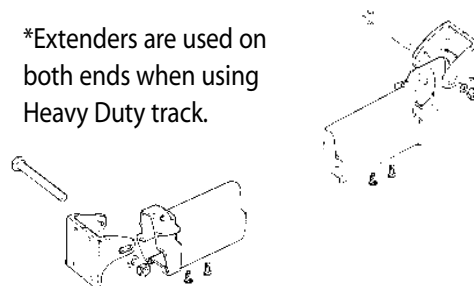

Step 3 Install Tracks

Insert an *Extender* into one end of the track. Do not install screws at this time.

Swing the opposite end of the track up and fasten it to the opposite *End Mounting Bracket*, (furthest from house) using the same type 2-3/4" bolt (C) and nut (D) used at the other end. Tighten the nut just snugly ... do not over-tighten. Repeat for each track provided.

Return to the end of the tracks where the *Extenders* are located ... move the *Extenders* back and forth until the two holes in the bottom of the track align with two holes in the *Extender*. Install two 3/4" Tapping Screws (A) and tighten.

Snugly tighten the nut on the bolt holding the *Extender* to the *End Bracket*. Do not over-tighten.

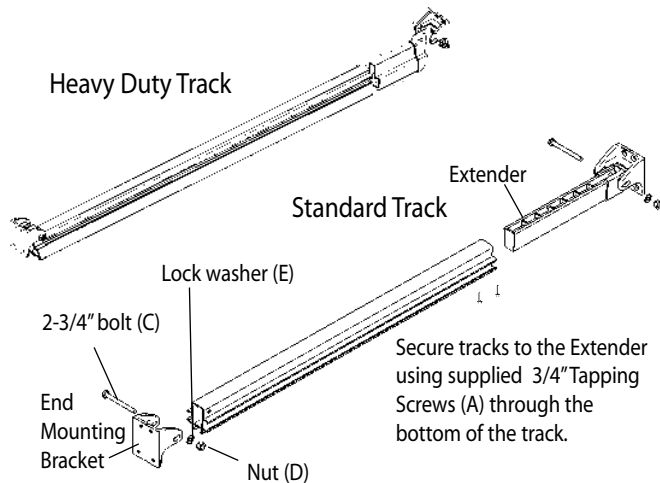

Step 4 Installing the Canopies

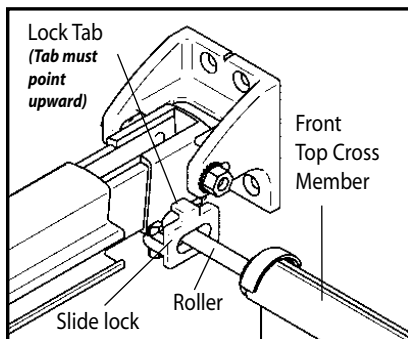

You can now insert the canopies, starting at the end of the tracks closest to the house. Insert the *Rollers* of the front *Cross Member* first. The front *Cross Member* is the one that has a *Slide Lock* on the roller at each end.

When inserting, ensure the lock tab is pointing up as shown here. Be sure the canopy is oriented so the *Fabric Clamp* is facing up as shown. Continue inserting the remaining *Rollers* until the entire canopy is up. Install the remaining canopies using the same procedure.

Step 5 Locking the End of the Canopy

Position the *Roller Lock Pin* in the track at the point where you want the canopy positioned. Once in place, it can be secured with the set screw. Repeat on each track. (On masonry houses, it is recommended to leave a few inches between the canopy and the house to prevent scuffing of the canvas during windy weather) .

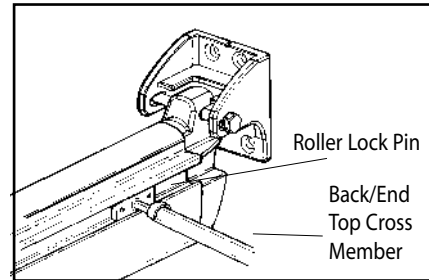

Step 6 Installing the Top Lock Brackets

Pull each canopy section out to the position where you want it to end. Place a *Top Lock Bracket* on the top of the track. Tighten the set screws with the Allen wrench provided (F) ... making sure the *Top Lock Brackets* are completely pushed down on the track before tightening.

Test the slide lock in the *Top Lock Bracket* and tighten or loosen the adjusting screws as required for the desired tension. Turn the adjust screw clockwise for greater tension; turn counter clockwise for less tension. Repeat this step for each *Top Lock*.

Pull each canopy back to the fully retracted position. Place another *Top Lock Bracket* on each track at this point to hold the canopies in retracted position. Tighten the set screws.

NOTE: The locking system is designed to release the canopies in high winds to protect the canopies. The adjusting screws can be used to adjust the tension. Do not over-tighten as this could increase the chance for canopy damage in high winds.

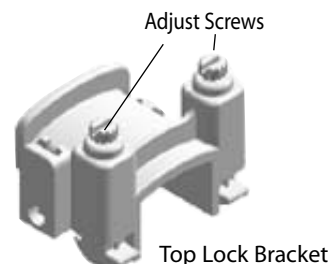

Note: Top Lock Bracket should face away from the house for the retracted position and to the house for the extended position.

Step 7 Adjusting Handle Height (optional)

Each canopy has the handle overhang approximately 18" from the tracks. This drop handle is for opening and closing the canopies, but it is also important for catching the wind to cause the wind-release mechanism to activate. Therefore, we encourage you NOT to shorten it. However, if you must have less than an 18" overhang, follow the instructions below for shortening the handle height.

1. Remove the screws in the handle and open the handle the entire width.
2. Cut the fabric to the desired length.
3. Carefully close the handle and re-insert the screws provided – do not overtighten.
4. Reinstall the top caps in the end of the handle.

Step 8 Shortening Track Length (optional)

If your application requires track lengths in a shorter increment than provided, then you can cut the track using a hacksaw or miter saw. Ensure that the cut is square. **Cut the excess length from the end of the track that has the 1/4" side holes.**

Once the cut has been made, two 1/4" mounting holes must be redrilled. Refer to the figure below for the location.

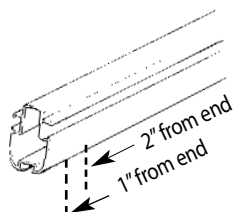

* for **Heavy-Duty** Track, two 5/16" holes need to be made on center at 1" from the end on the bottom and 2" from the end on the bottom. This is because the Heavy-Duty Track requires extenders on both ends.

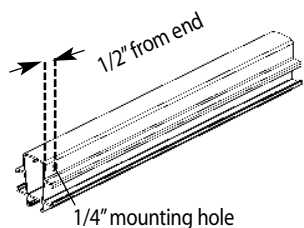

Standard Track

If you have shortened the track length, you will also need to shorten the canopy length, see the step, Step 9.

Step 9 Shortening Canopy Length (optional)

Lay the canopy on a flat clean surface. The extra fabric length should be removed from the back end of the canopy. This is the end opposite the handle. Remove the *Roller Sleeve* assemblies at both ends of the back canopy *Cross Member*. To do this, first fully extend the *Roller*, then push down on the locking tab and pull *Roller Sleeve* outward (Fig. 2A).



Remove the *Fabric Clamp*. To do this, insert a flat head screw driver between the canopy fabric and the *Fabric Clamp*. Pry upward to release the *Fabric Clamp* (Fig. 2B).



From the back end of the canopy, measure the same distance that was taken off the track length. Make a mark at this distance on both outside edges of the fabric (Fig. 2C).



Place the *Bottom Cross Member* (aluminum) underneath the canopy, centering it on the two marks. Position the *Bottom Cross Member* so the punched square holes at the ends are facing downward. Holding the *Bottom Cross Member* in this position, reassemble the *Fabric Clamp* by snapping the *Fabric Clamp* in place at both ends and pressing down, working toward the center (Fig. 2D).



Insert the *Roller Sleeve* assemblies back into the *Bottom Cross Member*, ensuring that the locking tab engages the corresponding punched square hole in the *Bottom Cross Member* (Fig. 2E).



Measure the canopies to ensure the desired length is correct before trimming off excess canopy material. Remove the canopies and place on a flat, clean surface. To remove the excess canopy material, use the edge of the *Fabric Clamp* as a guide when cutting with a sharp utility knife (Fig. 2F).

Care and cleaning of your ShadeTree® Canopies

1. **ShadeTree® tracks** should be cleaned regularly to keep debris and dirt from accumulating and interfering with the rollers. Simply use a mild detergent with a small soft brush, such as a toothbrush, and gently wipe or brush along the inside of the tracks. To maintain a smoothly operating system, apply a paste car wax such as Kit™ or Turtlewax™ to the roller tracks. Allow the wax to dry then wipe off with a clean, soft cloth. **Note: Do NOT use oil or any wet lubricant, such as WD-40, on the tracks as it would attract more dirt.** For ultimate performance, use **ShadeTree® EasyRider Track Lubricant**.
2. **Fabric** should be cleaned regularly before substances such as dirt, roof particles, etc., are allowed to accumulate on and become embedded in the fabric. The fabric can be cleaned without being removed from the cross members. Simply brush off any loose dirt, roof particles, etc.; hose down and clean with a mild natural soap in lukewarm water (no more than 100° F.) Rinse thoroughly to remove soap. **DO NOT USE DETERGENTS!** For ultimate performance, use **ShadeTree® Canopy Cleaner Mold & Mildew Stain Remover**.
3. For stubborn stains soak the fabric for approximately 20 minutes in a solution of no more than 1/4 cup (2 oz.) natural soap per gallon of water at approximately 100° F. Rinse thoroughly in cold water to remove all of the soap. Note: Excessive soaking in bleach can deteriorate sewing threads. This method of cleaning may remove part of the water repellency and the fabric should receive an application of an air-curing water-repellent treatment, such as APCO, UNISEAL, SUNSEAL or similar products, if water repellency is a factor. For ultimate performance, use **ShadeTree® Canopy Cleaner Mold & Mildew Stain Remover** and **ShadeTree® Water Repellent**.
4. When washing or cleaning, **DO NOT SUBJECT TO EXCESSIVE HEAT** as the fabric will shrink. **DO NOT STEAM PRESS OR DRY IN ELECTRIC OR GAS DRYERS**, but allow to air dry.
5. In cases where canopies are taken down & stored, they should be cleaned and allowed to air dry, before being stored in a dry, well ventilated area.

How to remove ShadeTree® Canopies for end-of season storage:

1. Remove the **Top Lock Brackets** at the “retracted” end of each track (see step 9.)



2. Loosen the **Roller Pin Lock** which holds the last Cross Member in a fixed position (see step 8.)



3. Then simply roll the **Cross Members** out of the “retracted” end of the track. The tracks can remain up year-round.
4. **If a canopy is dirty** and requires washing before storage, simply spread the canopy on a driveway or other flat surface. Wash, using a broom and bucket of warm water and a mild soap, such as Ivory Snow.

Be sure to rinse well by hosing with a clear water. Allow to air-dry completely in the sun before rolling canopies up for storage. **(Do not store wet canopies!)**

Here's a chance to earn \$50!

We regularly use pictures in our advertising materials. If you send us reproducible pictures of your new ShadeTree® canopy installation, and we use them in any of our advertising, we will send you \$50. Interesting before-and-after pictures will receive an additional \$50. Of course, attractive landscaping and patio furniture will be a factor in selecting pictures to be used. Architects, builders and installers will receive credit mentions in the advertising.

ShadeTree® Canopy System Products

What/who is covered and for how long

ShadeTree® Systems, LLC (ShadeTree) warrants to the original property owner/purchaser that its ShadeTree Canopy System products, when subject to normal and proper use, will be free from the manufacturing defects enumerated below. Should any enumerated defects occur during the specified time period following installation, ShadeTree will repair the defective ShadeTree System product or provide replacement material, at its option. ShadeTree also reserves the right to refund to the original owner the amount paid by the original owner for the defective ShadeTree System product (but not including the cost of labor related to its initial installation).

ShadeTree shall in no event be liable for labor charges or other expenses whatsoever in connection with removal or installation of either the original or replacement product. In the event of repair or replacement under the terms of this warranty, the original warranty shall apply to the replacement or repaired ShadeTree System component and will extend for the balance of the warranty period in effect at the time the component proved defective.

ShadeTree® Canopy System components carry the following warranties:

Canopy fabric

All fabrics are warranted by ShadeTree® for five years following installation against fading, rotting and mildew.

Posts, aluminum and vinyl tracks

All posts and overhead tracks are warranted for ten years following installation against breakage.

System hardware

All connectors and other hardware are warranted to remain operable for five years following installation.

Limitations

This warranty does not provide protection against any failure, defect or damage caused by situations and events beyond normal exposure conditions, including, but not limited to:

- misuse, abuse, neglect or improper handling or storage;
- improper installation or installation not in strict adherence to ShadeTree's written instructions;
- use of accessories which do not properly receive and/or secure ShadeTree® Canopy System products;
- impact of foreign objects, fire, earthquake, flood, high winds, lightning, hail, hurricane, tornado or other casualty or act of God;
- movement, distortion, collapse or settling of the ground or structure on which the ShadeTree® Canopy System product is installed;
- any other cause not involving enumerated manufacturing defects in the Canopy System product supplied by ShadeTree.

Transferability

This warranty is not transferable.

Other conditions

This warranty replaces all other oral or written warranties, liabilities or obligation of ShadeTree, pertinent state law shall control for what period of time following the sale a property owner/consumer may seek a remedy under the implied warranty of merchantability or of fitness for a particular purpose. In no event shall ShadeTree be liable for consequential or incidental damages of any kind resulting from the breach of this warranty. No field representative of ShadeTree or any distributor or dealer is authorized to make any change or modification to this warranty. Some states do not allow limitations on, or the exclusion of, incidental or consequential damages, so the above exclusions may not apply to you.

The warranty value is "pro-rated" based on invoice date and is not a full replacement warranty.

This warranty gives you specific legal rights, and you may also have other rights which may vary from state to state.

What the consumer must do:

The property owner/consumer must keep the original invoice as proof of date of purchase and installation, in case a warranty claim is made.

Notify ShadeTree in writing of any manufacturing defect promptly following its discovery and provide proof of the date of purchase and installation, as well as proof of property ownership. All notifications should be sent to:

ShadeTree® Systems, LLC
6317 Busch Blvd.
Columbus, OH 43229
Attn: Warranty Service Department

The property owner/consumer will be required to submit the defective material to ShadeTree for analysis. (ShadeTree will accept pictures of the larger items such as posts, and tracks.) ShadeTree will then investigate the claim and examine the material claimed to be defective. ShadeTree, at its sole discretion, will determine if a warranty claim is justified or not. If a defect covered by this warranty is confirmed, ShadeTree, within a reasonable amount of time after the inspection, will repair or provide replacement material, or refund the amount paid by the original owner for the defective product per the terms of this warranty.



This warranty is effective for products purchased after October 15, 2001.



Retractable Patio & Deck Canopies

ShadeTree® Systems, LLC

6317 Busch Blvd.

Columbus, Ohio 43229

800-894-3801

www.shadetreecanopies.com

40-75-136

Printed in U.S.A.